

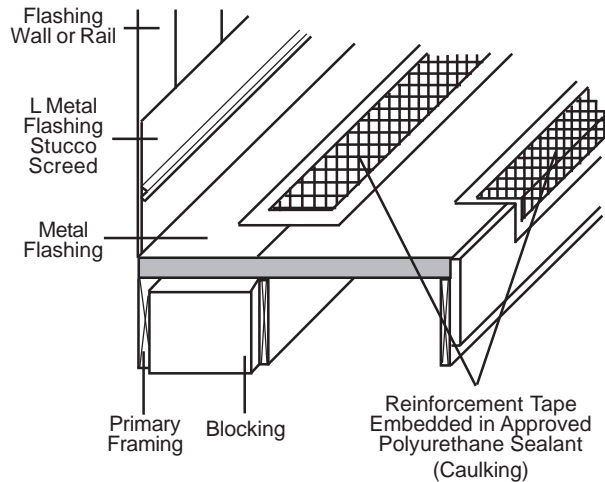

The following sketches provide guidelines for the installation of Polycoat Products coating systems. These details should be used as a guideline only. Decisions on final details should be made by the applicator after evaluating site conditions, code requirements and other standards.

For detailed information on the installation of the Polycoat Products waterproofing systems, refer to the general guidelines and individual system guide specifications.

FLASHING DETAIL



CRACK DETAIL

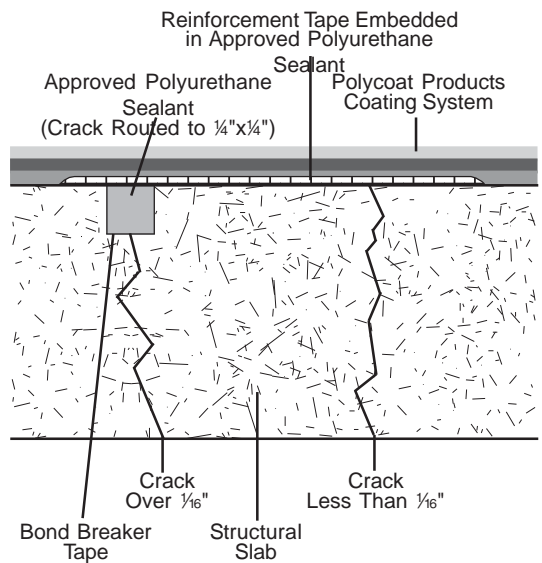

CRACK CONTROL

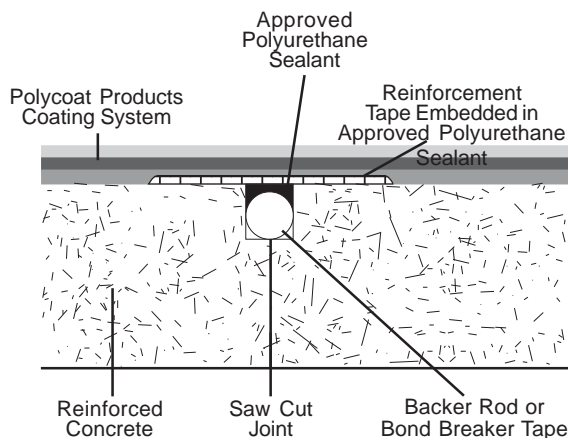

TERMINATION DETAIL

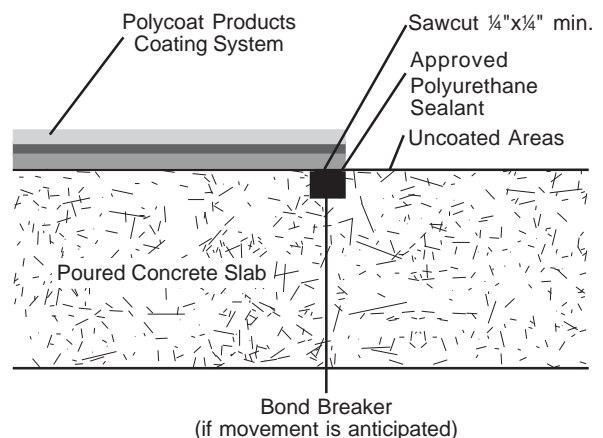

VERTICAL PROJECTION

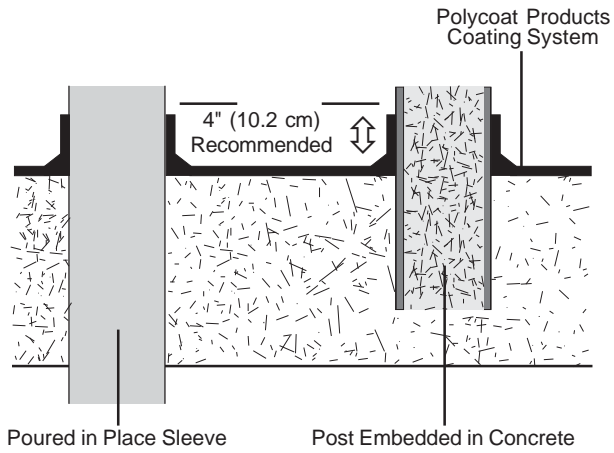

VERTICAL PROJECTION BETWEEN SLAB

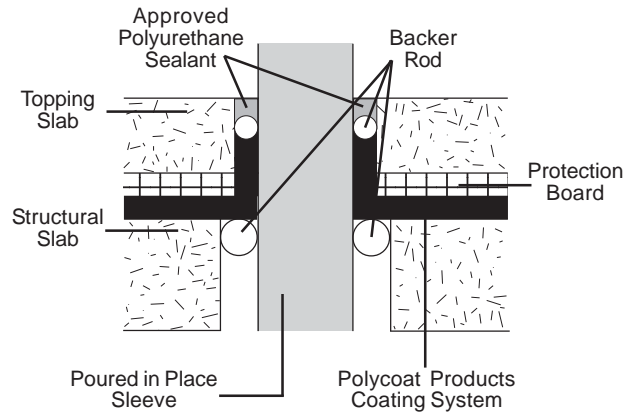

EXPANSION JOINT DETAIL (Greater Than 1")

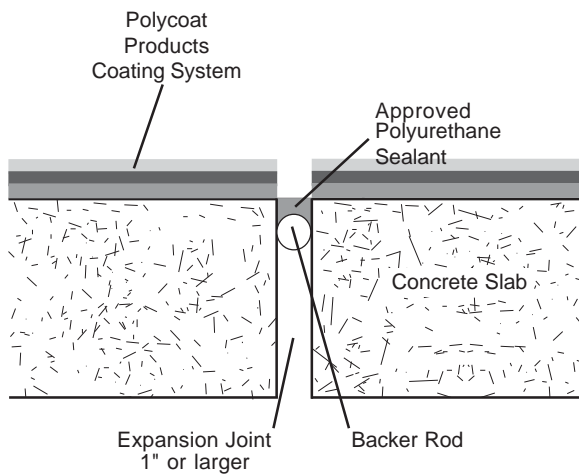

EXPANSION JOINT DETAIL (Less than 1")

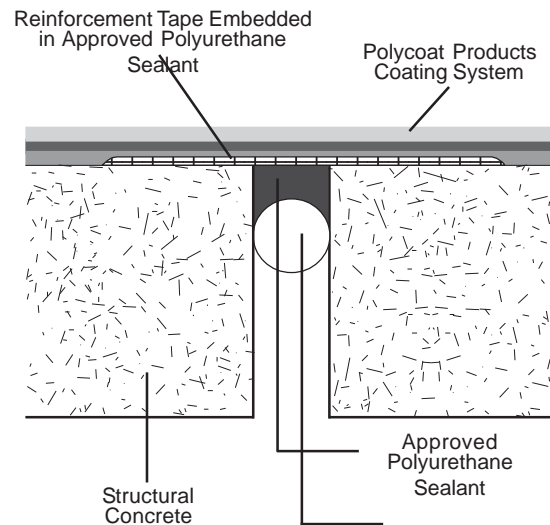

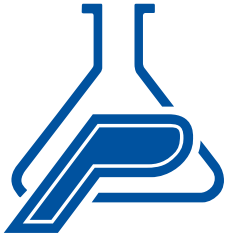

**POLYCOAT
PRODUCTS**
A Division of American Polymers Corp.

JOINT AT WALL/SLAB

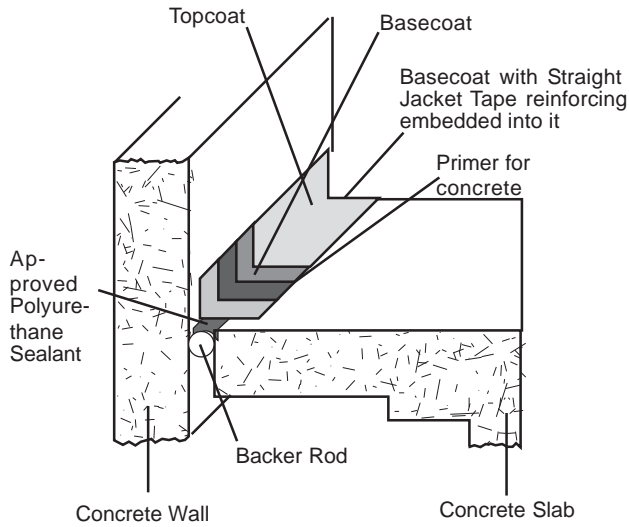

WALL BEARING ON SLAB

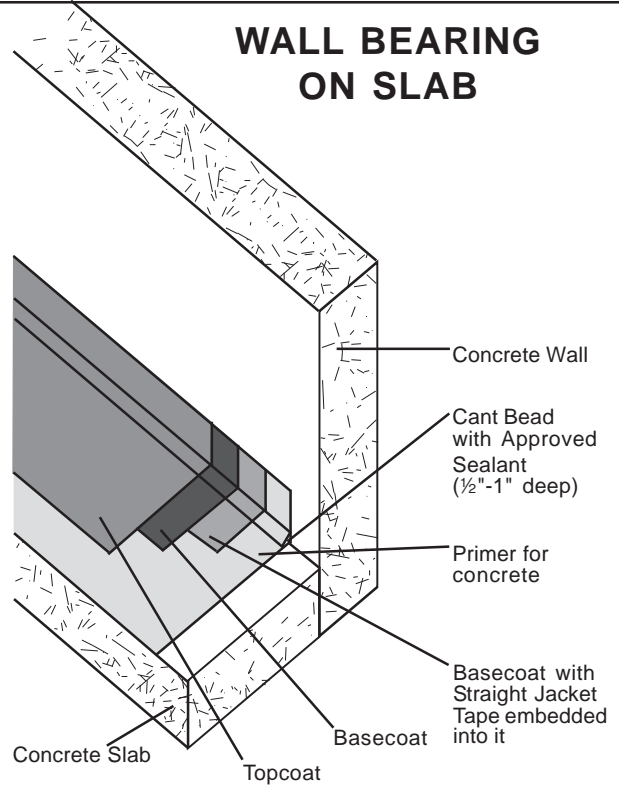

DRAIN DETAIL

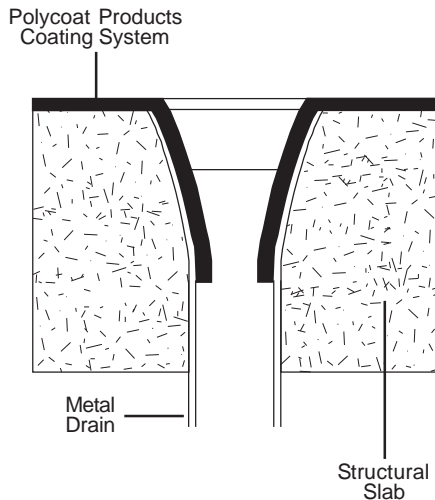

BETWEEN SLAB

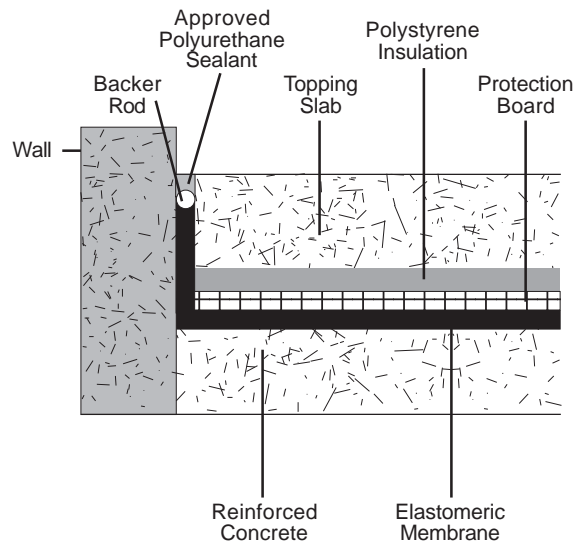

WALL / FOOTING

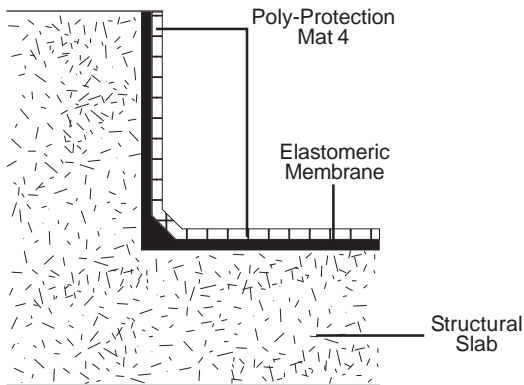

REFLECTING POOLS

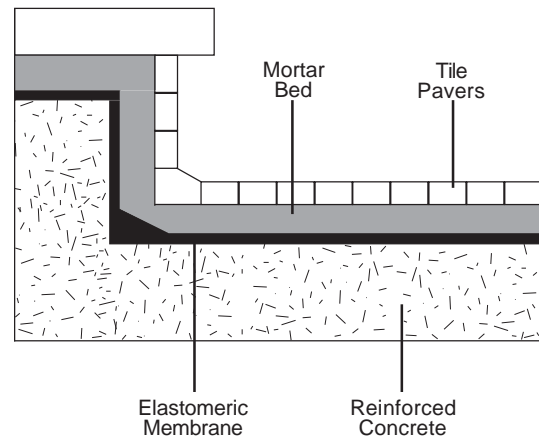

PLANTER BOX

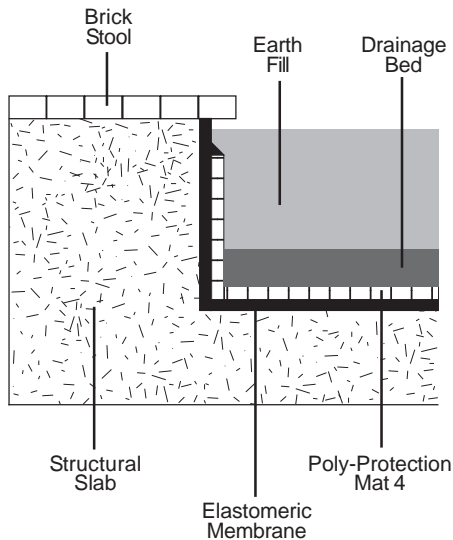

THIN SET TILE

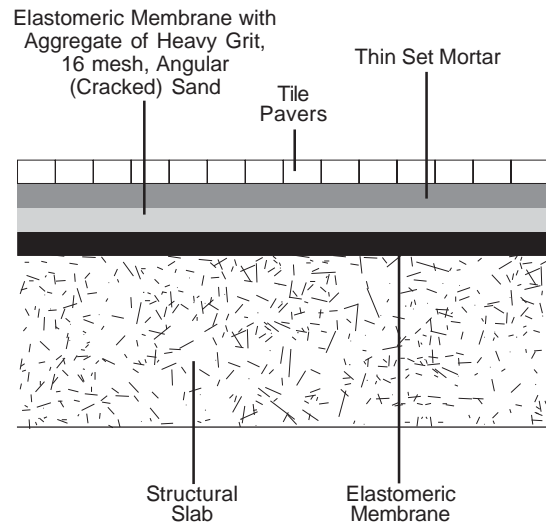

Please read all information in the general guidelines, product data sheets, guide specifications and material safety data sheets (MSDS) before applying material. Published technical data and instructions are subject to change without notice. Contact your local Polycoat Products representative or visit our website for current technical data and instructions.

DISCLAIMER

All guidelines, recommendations, statements, and technical data contained herein are based on information and tests we believe to be reliable and correct, but accuracy and completeness of said tests are not guaranteed and are not to be construed as a warranty, either expressed or implied. It is the users responsibility to satisfy himself, by his own information and test, to determine suitability of the product for his own intended use, application and job situation and user assumes all risk and liability resulting from his use of the product. We do not suggest or guarantee that any hazard listed herein are the only ones which may exist. Neither seller nor manufacturer shall be liable to the buyer or any third person for any injury, loss or damage directly or indirectly resulting from use of, or inability to use, the product. Recommendations or statements, whether in writing or oral, other than those contained herein shall not be binding upon the manufacturer, unless in writing and signed by a corporate officer of the manufacturer. Technical and application information is provided for the purpose of establishing a general profile of the material and proper application procedures. Test performance results were obtained in a controlled environment and Polycoat Products makes no claim that these tests or any other tests, accurately represent all environments.